

morphyrichards®

Ultralight vacuum cleaner

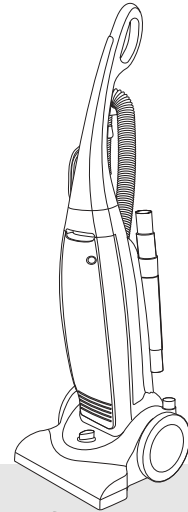

Please read and keep these instructions



UK

Helpline 0870 060 2603
Replacement parts 0870 167 6634

Ireland

1800 409119

getting the best from
your new cleaner...

If your cleaner isn't picking up as well as it should, please check

• **Dustbag**

It is important to replace them when full, otherwise the performance of the cleaner will be impaired

• **Filters**

It is important that the filters are cleaned and replaced regularly to allow air through the appliance

• **Blockages**

Check the hose for blockages

• **Belt**

Check and replace damaged or broken belt



www.morphyrichards.co.uk

Important safety instructions

The use of any electrical appliance requires the following of common sense safety rules.

Primarily there is danger of personal injury and secondly danger of damage to the appliance and property. These are indicated in the instructions text by the following two conventions:

WARNING: Danger of personal injury

IMPORTANT: Damage to the appliance

In addition we offer the following essential safety advice.

Location

- Do not use or keep this product outside when it is raining.
- Do not store the appliance near hot ovens or heating appliances.

Mains lead

- Do not allow the mains lead to become strained or run this appliance over it.
- If the electrical cable becomes damaged the complete cable assembly must be replaced. Do not attempt this task yourself, contact Morphy Richards using the helpline number.

Children

- Children do not understand the dangers associated with operating electrical appliances. Never allow children to use this appliance.

Other safety considerations

- Never use in the presence of explosive liquids or vapours.
- Never pick up inflammable or poisonous liquids such as petrol, copier toner, or other volatile substances. Never pick up acids, asbestos or asbestos dust.
- Never use the appliance without the bag or filters installed.
- Never use the appliance to vacuum hot ashes, broken glass, sharp objects or

- liquids.
- Never modify the cleaner in any way.
- Always disconnect the appliance from the mains supply after use or prior to cleaning or replacing dust bags.
- The appliance should never be left running unsupervised.
- Repairs to electrical appliances are only to be undertaken by trained personnel. Unprofessional repairs can be dangerous for users.
- Use only genuine Morphy Richards spare parts and accessories
- Never over-extend the hose such that the cleaner is pulled over. If the cleaner is knocked over, switch off before attempting to upright.
- Never pick the cleaner up by the floor nozzle when connected to the mains, use the carrying handle.
- **WARNING: Keep loose clothing, hair, fingers etc. away from the floor nozzle whenever the cleaner is connected to the mains.**
- Disconnect from the mains supply before attempting to clear blockages, clear the brush or replace the belt.

Electrical requirements

Check that the voltage on the rating plate of your appliance corresponds with your house electricity supply which must be A.C. (Alternating Current).

If the socket outlets in your home are not suitable for the plug supplied with this appliance, the plug should be removed and the appropriate one fitted.

WARNING: The plug removed from the mains lead, if severed, must be destroyed as a plug with bared flexible cord is hazardous if engaged into a live socket outlet.

Should the fuse in the 13 amp plug require replacement, a BS1362 13 amp fuse must be fitted.

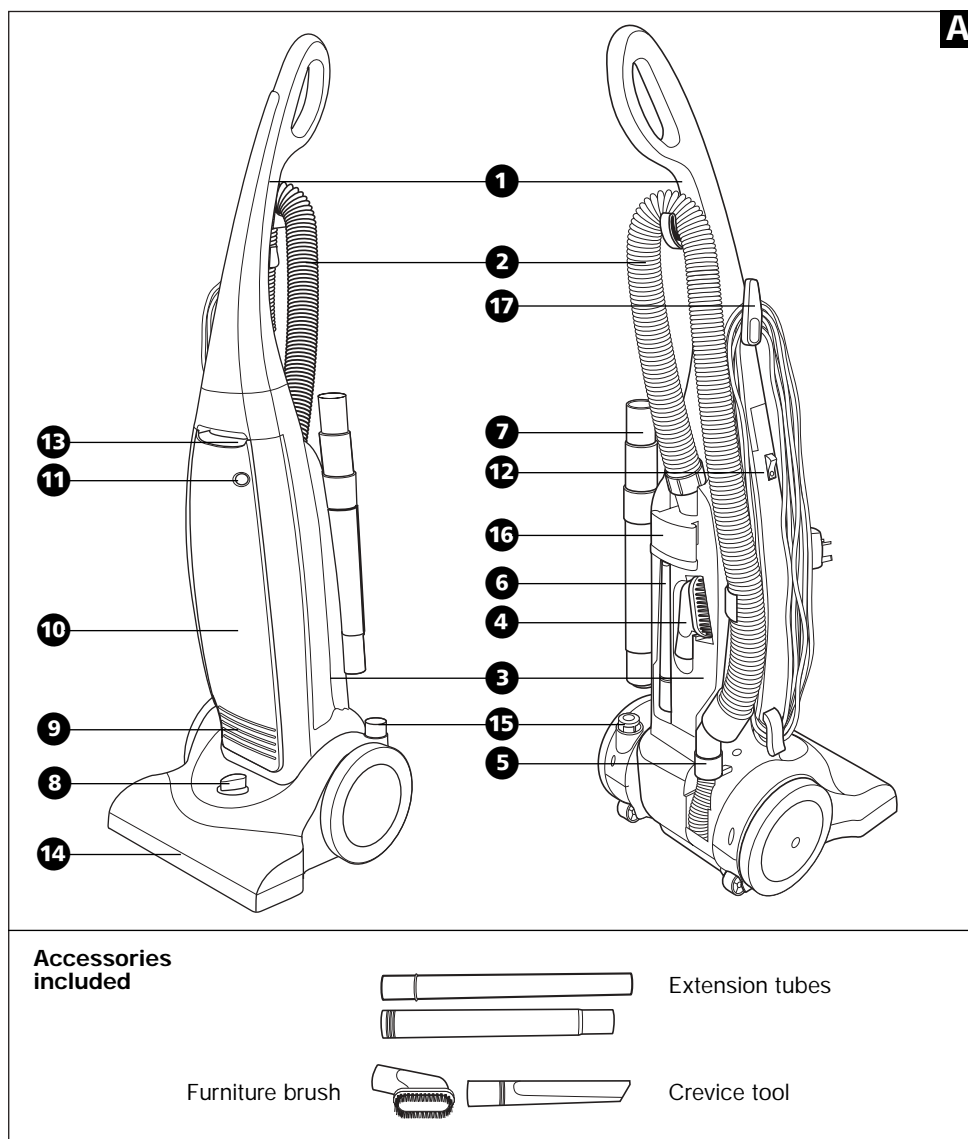

Features

- 1 Upper handle
- 2 Flexible hose
- 3 Main body
- 4 Furniture brush
- 5 Hose connector
- 6 Crevice nozzle
- 7 Nested extension tubes (2)
- 8 Carpet height adjustment knob
- 9 Exhaust filter
- 10 Front panel
- 11 Full bag indicator
- 12 On/Off switch
- 13 Front cover release
- 14 Floor nozzle with powered brush
- 15 Handle release
- 16 Carrying handle
- 17 Cord storage with quick release cleat
- 18 Safety bag interlock (shown page 5)
- 19 Belt cover (page 6)
- 20 Brush bar (page 6)

Assembly E

Warning: Do not plug in the cleaner until it is assembled.

- 1 Carefully unpack all components.
- 2 Lift cleaner body to upright position.
- 3 Remove the two screws that are already attached to the body.
- 4 From the rear of the cleaner, align the handle with groove and slide into the body. If necessary, use thumb and finger pressure to slide handle into position.
- 5 Fasten the handle with the two screws.

Floor nozzle height adjustment E

Before using the cleaner the floor nozzle height must be set to the correct height.

Choose the setting which most closely matches your floor surface, ie deep carpet pile, medium carpet pile, short carpet pile or hard floor.

When using the attachments the cleaner must only be used in the upright position with the carpet height adjustment knob set to deep carpet.

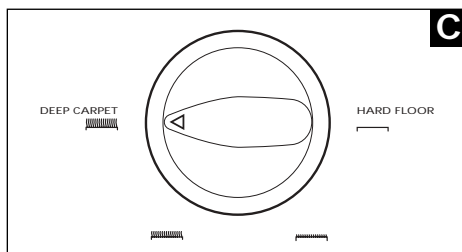
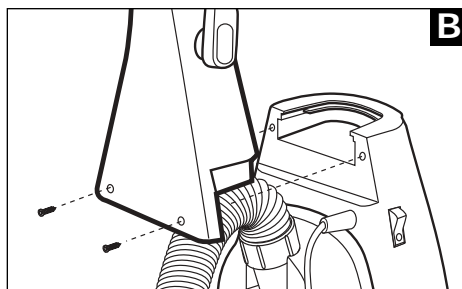

4

Using on carpets

- 1 Place cleaner in its upright position.
- 2 Set the carpet height adjustment knob to the desired position.
- 3 Release the mains cable by revolving the quick release cleat through 180° and extend the cable fully.
- 4 Plug the cable into the mains socket.
- 5 Step on the handle release button to release the handle to the desired position D.
- 6 Press the on/off button to the 'on' position.

IMPORTANT: To prevent damage to carpets, never leave the cleaner switched on in one place for an extended period.

- Never have the brushes set too low such that the cleaner is hard to push.

Using attachments

Follow steps 1-4 above but set the carpet height adjustment knob to the deep carpet setting.

- 5 Remove the hose connector from the rear of the cleaner and push the required attachment firmly onto the end of the hose.
- If additional length is required, attach one or both extension tubes between the hose and tool.
- 6 Switch on/off.

IMPORTANT: Never over extend the hose such that the cleaner is pulled over.

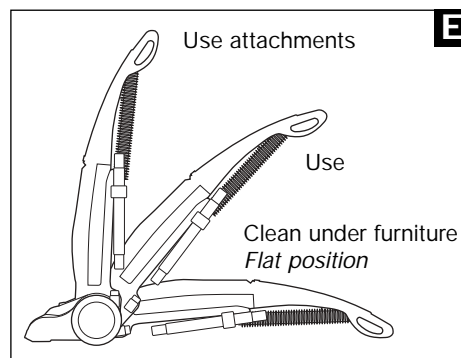

Dust bag condition

When the cleaner is switched on, if the dust bag condition indicator is continuously showing red (or if the suction is reduced) the bag must be replaced and the filters cleaned.

If it is still showing red after emptying the dust bag and cleaning the filters, check to see if the hose is blocked.

Changing the dust bag

- 1 Unplug power cable from wall socket.
- 2 Remove the front by pressing the release lever at the top.
- 3 Remove the old dust bag by holding the cardboard tab and pull towards you. Remove carefully to avoid dust/dirt spilling from dust bag and dispose.
- 4 Take a new dust bag and fold over the top tab at the crease. Holding the cardboard tab, push the bag over the opening of the dirt discharge tube until it is seated against the rear of the enclosure.
- 5 The front panel will not close unless the dustbag is correctly fitted due to the safety bag interlock. Always check the pre-motor and post motor filters every time you change the dust bag.
- 6 Once the new dust bag is in place, replace the front panel by aligning the bottom locking tabs with the slots in the body, close cover slowly allowing the front panel to snap in place. The latch will self lock.

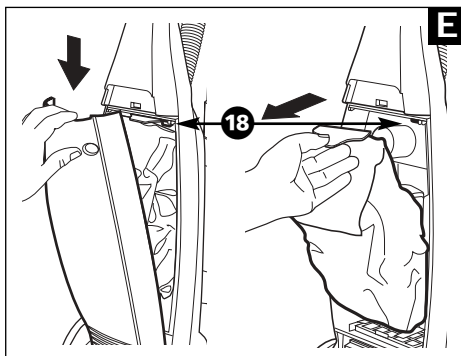

Changing the filters

Everytime a new bag is fitted, the filters should be taken out and cleaned. Failure to clean the filters will reduce the suction and will damage the motor if used for prolonged periods. This may invalidate the guarantee. If the filters become damaged they must be replaced.

IMPORTANT: Do not operate the cleaner without the filters in place.

- 1 Remove the front cover of the cleaner.
- 2 The pre-motor filter is located underneath the bag and the exhaust filter is below facing forward. To remove the pre-motor filter, simply slide it forward. To remove the exhaust motor filter, pull the locking tab on the right and it will snap out.
- 3 Remove the filters from their holders by unclipping and shake vigorously over a dustbin. The pre-motor filter may also be washed in warm water. Do not use detergents. The filter must be completely dry before re-fitting. Allow filter to dry naturally, do not overheat. The exhaust filter is non-washable.
- 4 Replace front cover.

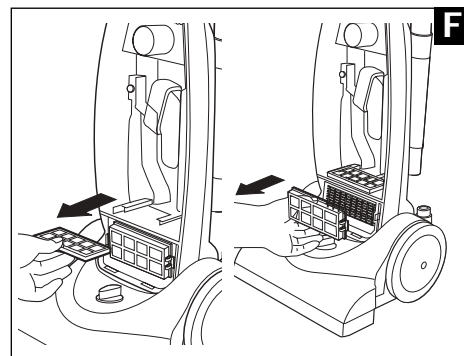

Changing the belt

If the power brush stops rotating it is likely that the drive belt has snapped (usually because the brush has been stalled). A spare belt is supplied. Replacement belts can also be obtained from Morphy Richards or a Service Agent.

Removing the floor nozzle cover **G**

- 1 Disconnect the cleaner from the mains supply.
- 2 Place the cleaner upside down in the flat position.
- 3 Use a cross-head screwdriver to remove the two screws at the front and the central screw under the height adjustment mechanism **G**.
- 4 Turn the cleaner over and remove the carpet height adjustment knob **5**.
- 5 Remove the two screws at the rear and

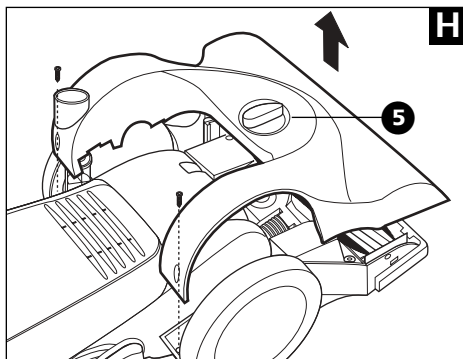
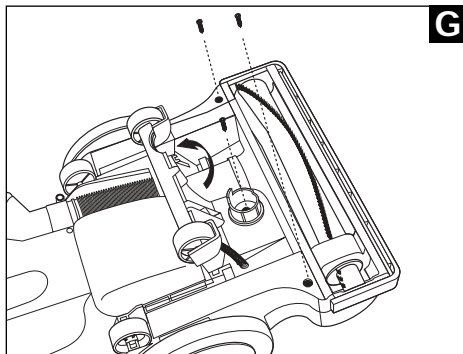

6

lift the rear of the cover over the handle release button and unclip the cover from the front of the floor nozzle **I**.

Replacing the belt **I**

- 6 If the belt has broken, ensure all pieces are removed.
- 7 Lift off the belt cover **19**.
- 8 Grasp the brush bar **20** at both ends and lift straight up.
- 9 Place one end of the new belt over the metal motor shaft pin and the other around the pulley end of the brush **J**.
- 10 Align brush end plates with their guide slots and push the brush bar down into place.
- 11 Re-fit the belt cover.
- 12 Re-fit the floor nozzle cover. Push the carpet height adjustment knob back on.
- 13 Replace the two screws on the top of the floor nozzle cover and the three screws underneath the floor nozzle - do not overtighten.

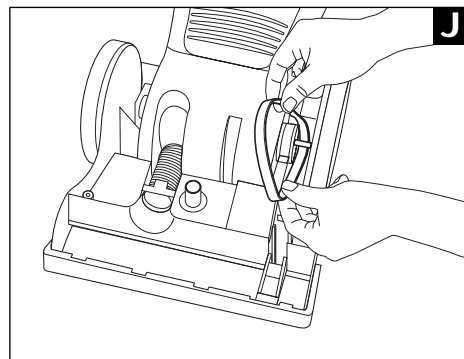
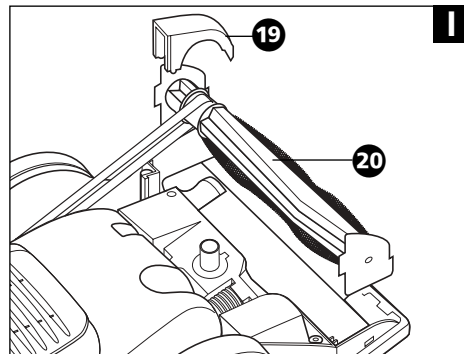

Safety cut-out

If the cleaner overheats a motor protection thermostat will automatically switch the motor off. If this happens, switch the cleaner off, unplug from the power supply and leave the cleaner to cool for at least 30 minutes. Check the airways for blockages, clean the filters and replace the dust bag before restarting.

Helpline

If you have any difficulty with your appliance, do not hesitate to call us. We're more likely able to help than the store from where you bought the product.

Please have the following information ready to enable our staff to deal with your query quickly:

- Name of the product
- Model number as shown on the underside of the appliance.



Your two-year guarantee

- **It is important to retain the retailers receipt as proof of purchase.** Staple your receipt to this back cover for future reference.

Please quote the following information if the product develops a fault. These numbers can be found on the rear of the product.

Model no. Serial no.

All Morphy Richards Products are individually tested before leaving the factory. In the unlikely event of any appliance proving to be faulty within 28 days of purchase it should be returned to the place of purchase for it to be replaced.

If the fault develops after 28 days and within 24 months of original purchase, you should contact the helpline number quoting model number and serial number on the product, or write to Morphy Richards at the address shown. You will be asked to return the product (in secure, adequate packaging) along with a copy of proof of purchase. Subject to the exclusions set out below (1-6), the faulty appliance will then be repaired or replaced and dispatched usually within seven working days of receipt.

If for any reason this item is replaced during the 2-year guarantee period, the guarantee on the new item will be calculated from original purchase date. Therefore it is vital to retain your original receipt or invoice

to indicate the date of initial purchase.

To qualify for the two-year guarantee the appliance must have been used according to the manufacturers instructions. For example bags and filters shall have been regularly cleaned or replaced.

Morphy Richards shall not be liable to replace or repair the goods under the terms of the Guarantee where:

- 1 The fault has been caused or is attributable to accidental use, mis-use, negligent use or used contrary to the manufacturers recommendations or where the fault has been caused by power surges or damage caused in transit.
- 2 The appliance has been used on a voltage supply other than that stamped on the products.
- 3 Repairs have been attempted by persons other than our service staff (or authorised dealer).
- 4 Where the appliance has been used for hire purposes or non-domestic use.
- 5 Morphy Richards are not liable to carry out any type of servicing work, under the guarantee.
- 6 Consumables such as bags, filters and belt are not covered by the guarantee.

This guarantee does not confer any rights other than those expressly set out above and does not cover any claims for consequential loss or damage. This guarantee is offered as an additional benefit and does not affect your statutory rights as a consumer.

- This guarantee is valid in the UK and Ireland only.

Morphy Richards products are intended for household use only

Morphy Richards has a policy of continuous improvement in product quality and design. The Company, therefore, reserves the right to change the specification of its models at any time.

morphy richards[®]

The After Sales Division,
Morphy Richards Ltd, Mexborough,
South Yorkshire, England, S64 8AJ

Helpline (office hours)
UK (local rate) 0870 060 2603
Republic of Ireland 1800 409119